

NOTE 1)

PHASE	OUTPUT	POLE	VOLT	AMP	WEIGHT
1 Φ	0.75 Kw	2 P	220 V	6.0 A	20.5 Kg

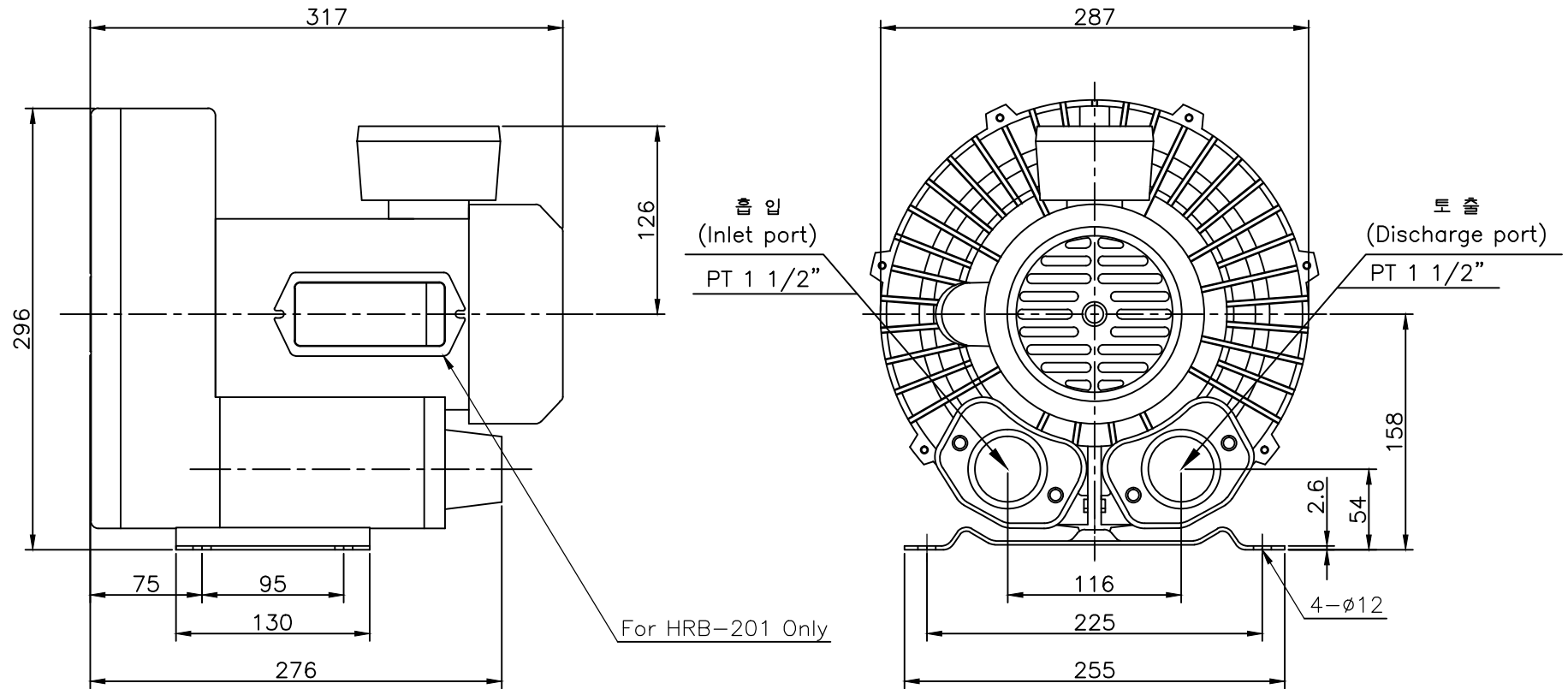

For HRB-201 Only

회주제품 구조				절삭 가공				No.				Revision				Date	Draw	Check	Appr.
보통 치수 허용차	길이		두께		치수 구분	정밀급	보통급	형식 TYPE				HRB-201		도명 TITLE		OUTLINE DWG			
	치수 구분	허용차	치수 구분	허용차	0 - 6	±0.05	±0.1	DRAWN	DESIGN	CHECKED	APPROVED	3RD ANGLE	SCALE:1/NS	UNIT:mm					
	0 - 120	±1.5	0 - 10	±1.5	6 - 30	±0.1	±0.2	B.S.Kim				SIZE	1φ 2P 0.75Kw						
	120 - 250	±2.0	10 - 18	±2.0	30 - 120	±0.15	±0.3	09.06.25				도번 DWG. No	BOD00132						
	250 - 400	±3.0	18 - 30	±3.0	120 - 315	±0.2	±0.5	黃海電機 HWANG HAE ELECTRIC		△									
400 - 500	±4.0	30 - 50	±3.5	315 - 1000	±0.3	±0.6													
500 - 1800	±6.0			1000 - 2000	±0.5	±1.2													
				2000 - 3150	±0.8	±1.6													